

WINE | Upright Cabinets

WINE COOLERS



RCS 85B

30 mm	K4	+1°C +9°C	C ENERGY CLASS	CC1	+25°C 60RH
LED					GAS R600a

DETAILS

Chromed shelves	Lock fitted as standard	Independent light switches for inner light

GENERAL FEATURES

- 85 Lt. Wine cellar free-standing installation
- External in black coated plate, black thermoformed internally
- Roll-bond evaporator system
- Automatic compressor cycle defrost
- Foaming Agent Cyclopentane (30mm per side)
- Mechanical thermostat
- Removable Gasket
- Inner horizontal LED light (with independent switch)
- Lock fitted as standard
- Double layer safety tempered glass
- Transparent glass
- Adjustable chromed shelf (3 Pcs) and chromed basket (1 Pcs)
- N.4 Adjustable feet
- Energy efficiency class: C

TECHNICAL SPECIFICATIONS

Capacity	85 L
Temperature	K4 (+1°C-+9°C)
Consumption	0.78 kWh/24h
Rated Power	65 W
Noise level	46 dB(A)
Net Weight	35 Kg
Gross Weight	38 Kg
External Dimensions (WxDxH mm)	505x590x780
Internal Dimensions (WxDxH mm)	410x395x625
Packaging dimensions (WxDxH mm)	580x620x810
Loading quantities 20'/40'/40'HQ	72/158/228

PRODUCT DIMENSIONS

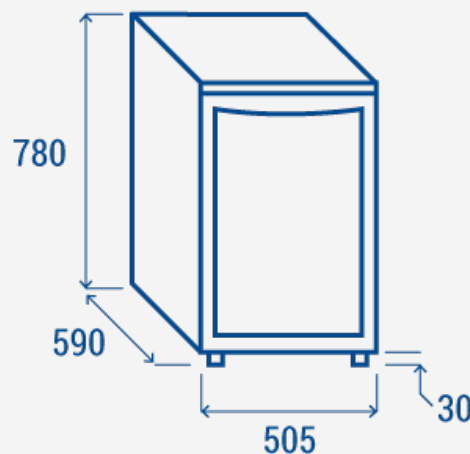

CERTIFICATION

CE RoHS



COOL HEAD EUROPE
We make the world a cooler place



www.coolheadeurope.com